





FCC 47 CFR PART 15 Subpart B

TEST REPORT

Equipment Dual-purpose switching Active Stylus Pen
Trademark N/A
Model No. XCR2-H
Report No. CTB200803011EX
Applicant Dongguan xiaochuang Electronic Technology Co., Ltd.
Room 802, no. 12, lane 11, nance wenming road, humen town,
dongguan city, Guangdong province
Manufacturer Dongguan xiaochuang Electronic Technology Co., Ltd.
Room 802, no. 12, lane 11, nance wenming road, humen town,
dongguan city, Guangdong province
Prepared by Shenzhen CTB Testing Technology Co., Ltd.
Floor 1&2, Building A, No. 26 of Xinhe Road, Xinqiao Street, Baoan
District, Shenzhen China
Tel: 086-4008-258-12
Fax: 086-0755-23208027
Date of Receipt Jul. 29, 2020
Date of Test(s) Jul. 30, 2020 ~ Jul. 31, 2020
Date of Issue Aug. 04, 2020
Test Standard(s) CFR47, FCC Part 15 Subpart B, ANSI C63.4: 2014

In the configuration tested, the EUT complied with the standards specified above.

Producer :  , Date : Aug. 04, 2020
Lisa Deng Engineer
Signatory :  , Date : Aug. 04, 2020
Sherwin Qian Director

Note: The results shown in this test report refer only to the sample(s) tested unless otherwise stated. This test report shall not be reproduced except in full, without prior written approval of CTB. This document may be altered or revised by CTB, personnel only, and shall be noted in the revision of the document.

Revision History

Rev.	Issue Date	Revisions	Effect Page	Revised By
0	Aug. 04, 2020	Initial Issue	All Page	Sherwin Qian

Table of Contents

1. GENERAL INFORMATION.....	4
1.1. Description of EUT.....	4
2. TEST SUMMARY.....	5
3. FACILITIES.....	6
3.1. Test Facility.....	6
3.2. Test Instruments.....	6
4. Measurement uncertainty.....	7
4.1. Operating condition of EUT.....	7
4.2. Test conditions.....	7
5. Conducted Emission.....	8
5.1. Limit.....	8
5.2. Test setup.....	8
5.3. EMI Test Receiver Setup.....	8
5.4. Test procedure.....	9
5.5. Test results.....	9
6. Radiated emissions.....	12
6.1. Limit.....	12
6.2. Test setup.....	12
6.3. EMI Test Receiver Setup and Spectrum Analyzer Setup.....	13
6.4. Test procedure.....	13
6.5. Corrected Amplitude & Margin Calculation.....	13
6.6. Test results.....	13
7. Photographs of test setup.....	16
8. Photographs of EUT.....	17

1. GENERAL INFORMATION

1.1. Description of EUT

Equipment	Dual-purpose switching Active Stylus Pen
Trade Mark	N/A
Model Name	XCR2-H
Serial No.	Not labeled
Model Difference	N/A
Operating Frequency	N/A
I/O Port	N/A
EUT Power Rating	DC 5V from adapter (AC 120V/60Hz), DC 3.7V from battery
Configuration	<input checked="" type="checkbox"/> Table-top <input type="checkbox"/> Floor-standing
Accessory Device	Adapter
Cable Supplied	N/A

Note:

1. Other Accessory Device List and Details

Description	Manufacturer	Model	Note
Adapter	JIYIN	JY-05100C	-

External I/O Cable

Cable Description	Shielded Type	Ferrite Core	Length(m)	Note
-	<input type="checkbox"/> Shielded <input type="checkbox"/> Non-shielded	<input type="checkbox"/> Yes <input type="checkbox"/> No		

2. The above EUT information is declared by manufacturer and for more detailed features description, please refer to the manufacturer's specifications or the User's Manual.

2. TEST SUMMARY

Test procedures according to the technical standards:

FCC Rules	Test Item	Test Result
§15.107	Conducted Emission	PASS
§15.109	Radiated Emission	PASS

Remark: N/A is abbreviation for Not Applicable.

The test was carried out in all the test modes, only the worst data are list in report.

3. FACILITIES

3.1. Test Facility

CTB-LAB

Floor 1&2, Building A, No. 26 of Xinhe Road, Xinqiao Street, Baoan District, Shenzhen China

3.2. Test Instruments

The following list contains measurement equipment used for testing. The equipment conforms to the requirement of CISPR 16-1, ANSI C63.2 and other required standards.

Calibration of all test and measurement, including any accessories that may effect such calibration, is checked frequently to ensure the accuracy. Adjustments are made and correction factors are applied in accordance with the instructions contained in the respective.

Table list of the test and measurement equipment

Conducted Emission Measurement

Item	Equipment	Manufacturer	Model No.	Serial No.	Calibrated until
1	AMN	R&S	ESH3-Z5	831551852	2020.10.30
2	Pulse limiter	R&S	ESH3Z2	357881052	2020.10.30
3	EMI test Receiver	R&S	ESCI	834115/006	2020.11.01
4	Coaxial cable	ZDECL	Z302S-BNCJ-BNCJ-1.5M	18091904	2020.10.30
5	CE Test software	FALA	EZ-EMC	Ver. EMC-con3A1 .1	N/A

Radiated Emission Measurement

Item	Equipment	Manufacturer	Model No.	Serial No.	Calibrated until
1	TRILOG Broadband Antenna	Schwarzbeck	VULB 9168	869	2020.11.02
2	Double Ridged Broadband Horn Antenna	Schwarzbeck	BBHA 9120 D	1911	2020.11.02
3	Preamplifier	Agilent	8449B	3008A01838	2020.11.01
4	Amplifier	HP	8447E	2945A02747	2020.11.01
5	Coaxial cable	ETS	RFC-SNS-100-NMS-80 NI	/	2020.11.01
6	Coaxial cable	ETS	RFC-SNS-100-NMS-20 NI	/	2020.11.01
7	Coaxial cable	ETS	RFC-SNS-100-SMS-20 NI	/	2020.11.01
8	Coaxial cable	ETS	RFC-NNS-100-NMS-300 NI	/	2020.11.01
9	EMI test Receiver	R&S	ESPI	100362	2020.11.01
10	MXA signal analyzer	Agilent	N9020A	MY52090073	2020.11.01
11	RE Test software	FALA	EZ-EMC	Ver. FA-03A2 RE	N/A

4. Measurement uncertainty

The following table is for the measurement uncertainty, which is calculated as per the document CISPR 16-4 and ANSI C63.4.

Test	Parameters	Expanded Uncertainty (U_{Lab})	Expanded Uncertainty (U_{Cispr})
Conducted Emission	Level Accuracy: 150kHz to 30MHz	± 1.22 dB	± 3.6 dB
Radiated Emission	Level Accuracy: 30MHz to 1000 MHz	± 3.67 dB	± 5.2 dB
Radiated Emission	Level Accuracy: Above 1000MHz	± 4.79 dB	N/A

This uncertainty represents an expanded uncertainty expressed at approximately the 95% confidence level using a coverage factor of $k=2$.

4.1. Operating condition of EUT

To investigate the maximum EMI emission characteristics generates from EUT, the test system was pre-scanning tested base on the consideration of following EUT operation mode or test configuration mode which possible have effect on EMI emission level. Each of these EUT operation mode(s) or test configuration mode(s) mentioned above was evaluated respectively

Pretest Mode	Description
Mode	Running

For Conducted Test	
Final Test Mode	Description
Mode	Running

For Conducted Test	
Final Test Mode	Description
Mode	Running

4.2. Test conditions

- Temperature: 15-35°C
- Relative Humidity: 30-60 %
- Atmospheric pressure: 800hPa-1060hPa

5. Conducted Emission

5.1.Limit

Except for Class A devices:

Frequency of emission (MHz)	Conducted limit (dB μ V)	
	Quasi-peak	Average
0.15-0.5	66 to 56*	56 to 46*
0.5-5	56	46
5-30	60	50

*Decreases with the logarithm of the frequency.

For Class A devices:

Frequency of emission (MHz)	Conducted limit (dB μ V)	
	Quasi-peak	Average
0.15-0.5	79	66
0.5-30	73	60

5.2. Test setup

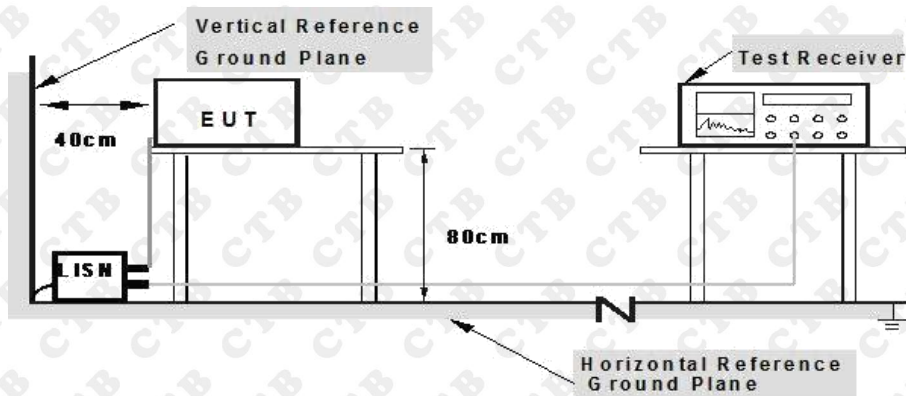

**Note: 1.Support units were connected to second LISN.
2.Both of LISNs (AMN) are 80 cm from EUT and at least 80 from other units and other metal planes**

The setup of EUT is according with ANSI C63.4 measurement procedure. Specification used with FCC Part 15 limits.

5.3.EMI Test Receiver Setup

Frequency Range	9kHz-30MHz
Resolution Bandwidth	200Hz (9kHz-150kHz) 9kHz (150kHz-30MHz)

5.4. Test procedure

Measurement was performed in shielded room, and instruments used were followed clause 4 of ANSI C63.4.

Detailed test procedure was following clause 7 of ANSI C63.4.

Frequency range 150kHz – 30MHz was checked and EMI receiver measurement bandwidth was set to 9 kHz.

5.5. Test results

PASS

Please refer to the following page.

Phase: L

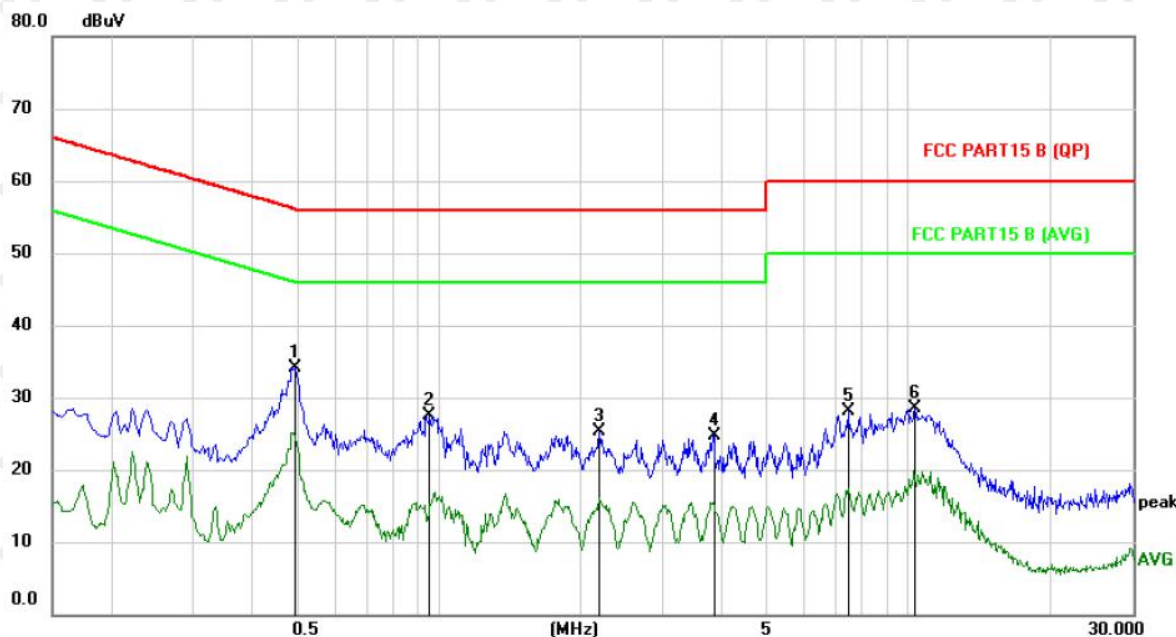

No.	Mk.	Freq. MHz	Reading Level dBuV	Correct Factor dB	Measure- ment dBuV	Limit dBuV	Margin dB	Detector
1	*	0.4940	24.01	10.05	34.06	56.10	-22.04	peak
2		0.9580	17.31	10.21	27.52	56.00	-28.48	peak
3		2.1980	15.05	10.24	25.29	56.00	-30.71	peak
4		3.8420	14.45	10.33	24.78	56.00	-31.22	peak
5		7.4220	17.67	10.47	28.14	60.00	-31.86	peak
6		10.2940	18.00	10.55	28.55	60.00	-31.45	peak

Note: Result=Reading + Factor
Over Limit=Result - Limit

Phase: N

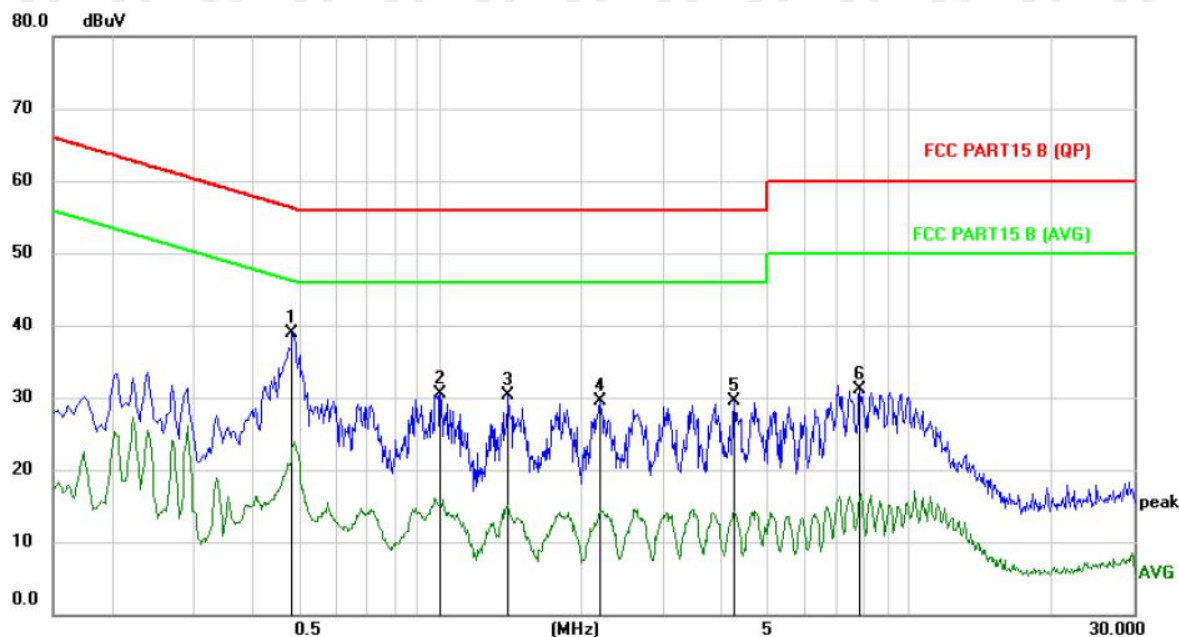

No.	Mk.	Freq. MHz	Reading Level dBuV	Correct Factor dB	Measure- ment dBuV	Limit dBuV	Margin dB	Detector
1	*	0.4860	28.62	10.23	38.85	56.24	-17.39	peak
2		1.0020	20.34	10.15	30.49	56.00	-25.51	peak
3		1.3980	20.24	10.15	30.39	56.00	-25.61	peak
4		2.1900	19.29	10.15	29.44	56.00	-26.56	peak
5		4.2300	19.07	10.41	29.48	56.00	-26.52	peak
6		7.8300	20.48	10.57	31.05	60.00	-28.95	peak

Note: Result=Reading + Factor
Over Limit=Result – Limit

6. Radiated emissions

6.1.Limit

Except for Class A devices (at 3m):

Frequency of emission (MHz)	Field strength (microvolts/meter)	
	(microvolts/meter)	(dB μ V/m)
30-88	100	40
88-216	150	43.5
216-960	200	46
Above 960	500	54

For Class A devices (at 10m):

Frequency of emission (MHz)	Field strength (microvolts/meter)	
	(microvolts/meter)	(dB μ V/m)
30-88	90	39
88-216	150	43.5
216-960	210	46.4
Above 960	300	49.5

6.2. Test setup

Radiated Emission Test Set-Up Frequency Below 1 GHz

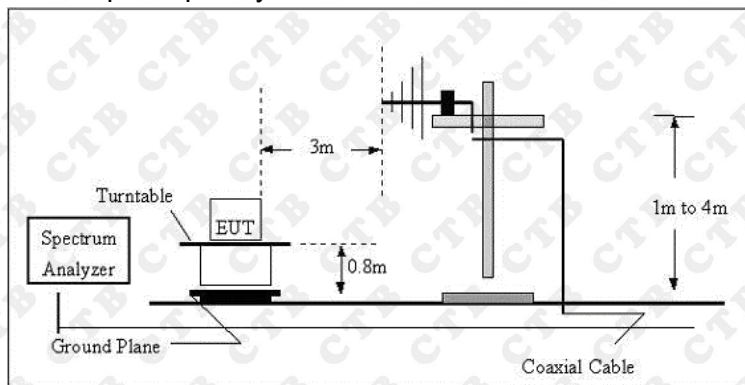

Radiated Emission Test Set-Up Frequency Above 1GHz

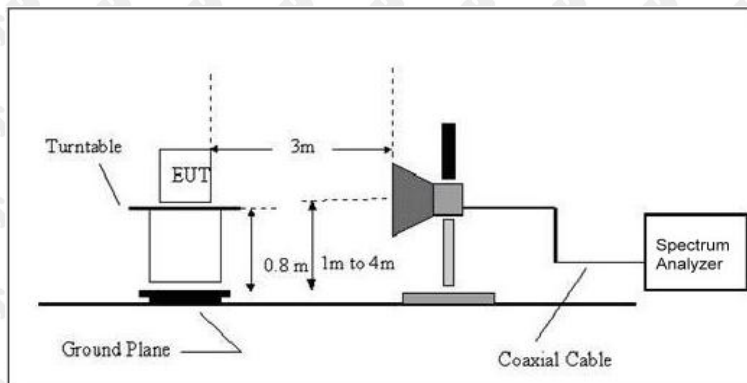

The radiated tests were performed in semi-anechoic(3m) test site, using the setup accordance with the ANSI C63.4:2014.

6.3.EMI Test Receiver Setup and Spectrum Analyzer Setup

During the radiated emission test, the EMI test receiver and Spectrum Analyzer were set with the following configurations:

Frequency Range	RBW	Video B/W	IF B/W	Detector
30MHz-1000MHz	100kHz	300kHz	120kHz	QP
Above 1GHz	1MHz	3MHz	/	PK
	1MHz	10Hz	/	AVG

6.4. Test procedure

The measurement was performed in a semi-anechoic chamber, and instruments used were followed clause 4 of ANSI C63.4.

Detailed test procedure was following clause 8 of ANSI C63.4.

6.5. Corrected Amplitude & Margin Calculation

The Corrected Amplitude is calculated by adding the Antenna Factor and Cable Loss, and subtracting the Amplifier Gain from the Meter Reading. The basic equation is as follows:

$$\text{Corrected Amplitude} = \text{Meter Reading} + \text{Antenna Factor} + \text{Cable Loss} - \text{Amplifier Gain}$$

The "Margin" column of the following data tables indicates the degree of compliance with the applicable limit. For example, a margin of 7dB means the emission is 7dB below the limit. The equation for margin calculation is as follows:

$$\text{Margin} = \text{Limit} - \text{Corrected Amplitude}$$

6.6. Test results

PASS

Please refer to the following page.

Polarization: H

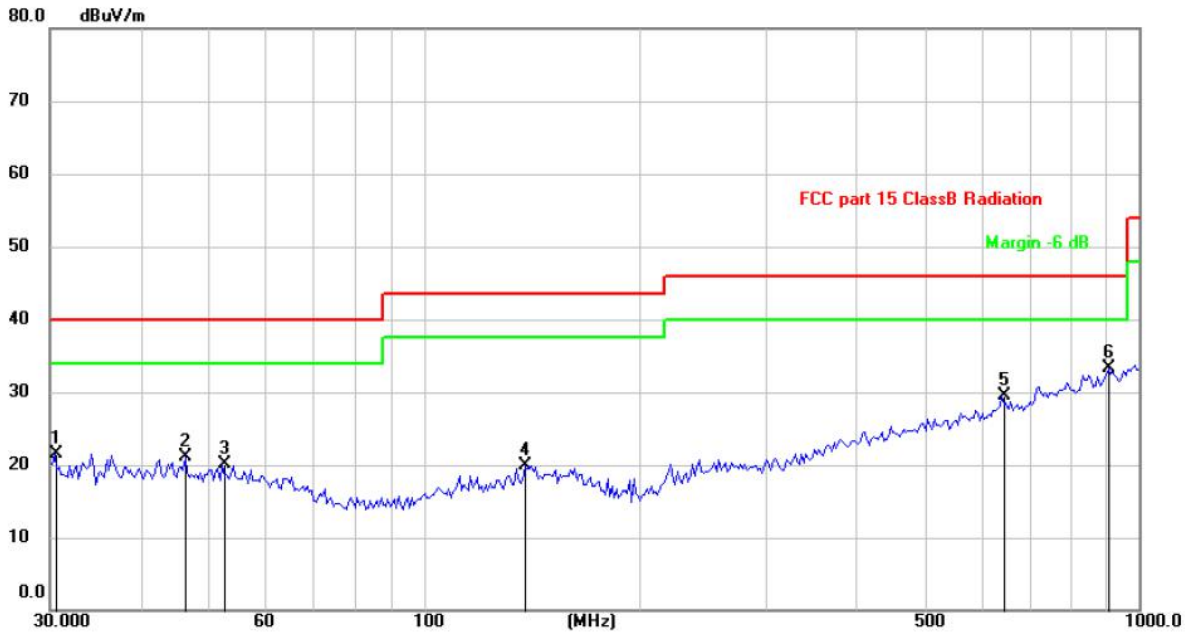

No.	Mk.	Freq. MHz	Reading Level dBuV	Correct Factor dB	Measure- ment dBuV/m	Limit dB/m	Margin dB	Detector
1		30.4238	29.07	-7.54	21.53	40.00	-18.47	peak
2		46.3402	26.92	-5.87	21.05	40.00	-18.95	peak
3		52.2079	26.45	-6.25	20.20	40.00	-19.80	peak
4		138.3873	26.48	-6.60	19.88	43.50	-23.62	peak
5		642.8613	26.67	2.76	29.43	46.00	-16.57	peak
6	*	906.4824	26.16	7.05	33.21	46.00	-12.79	peak

Note: Result=Reading+Factor
Over Limit=Result-Limit

Polarization: V

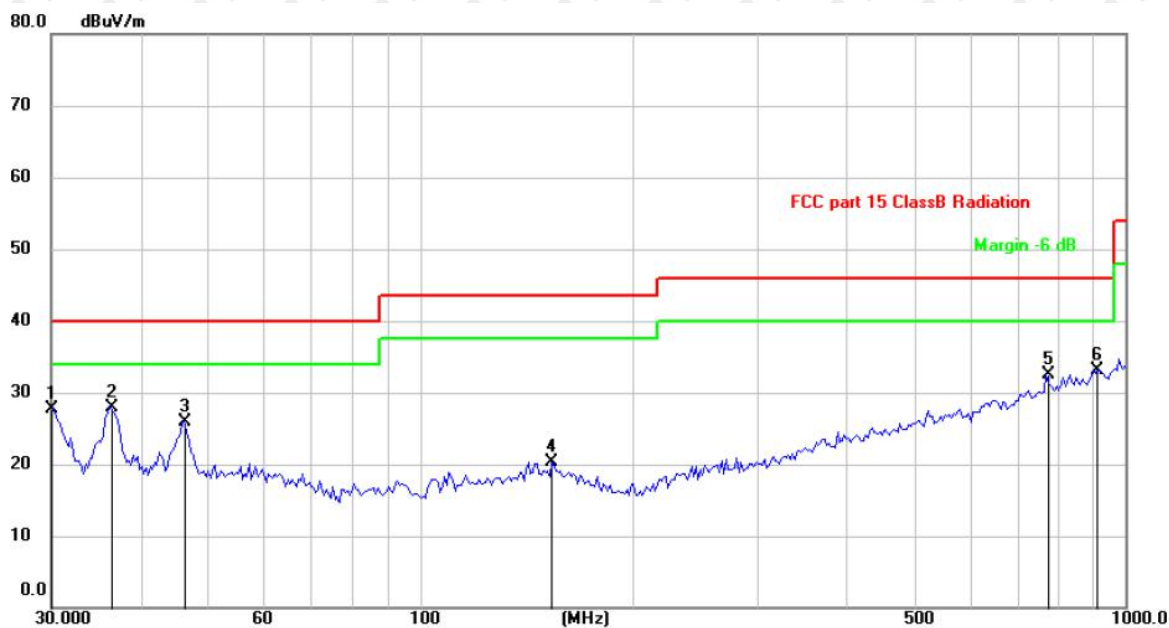

No.	Mk.	Freq. MHz	Reading Level dBuV	Correct Factor dB	Measure- ment dBuV/m	Limit dB/m	Margin dB	Detector
1		30.2111	35.24	-7.58	27.66	40.00	-12.34	peak
2	*	36.2541	34.34	-6.46	27.88	40.00	-12.12	peak
3		46.0164	31.68	-5.85	25.83	40.00	-14.17	peak
4		153.7385	26.53	-6.29	20.24	43.50	-23.26	peak
5		771.4486	27.18	5.28	32.46	46.00	-13.54	peak
6		912.8620	26.02	7.13	33.15	46.00	-12.85	peak

Note: Result=Reading+Factor
Over Limit=Result-Limit

7. Photographs of test setup

Photograph of test setup for Conducted Emission



Photograph of test setup for Radiated disturbance

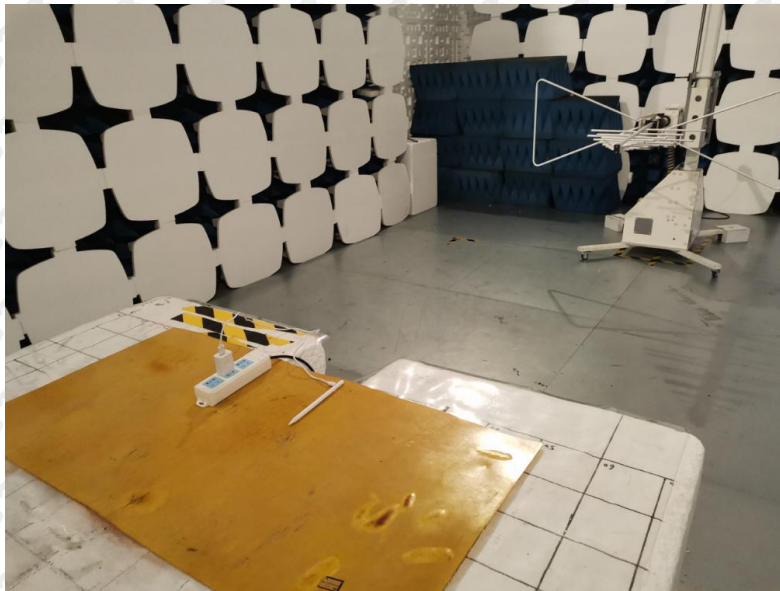

8. Photographs of EUT

Photographs of EUT

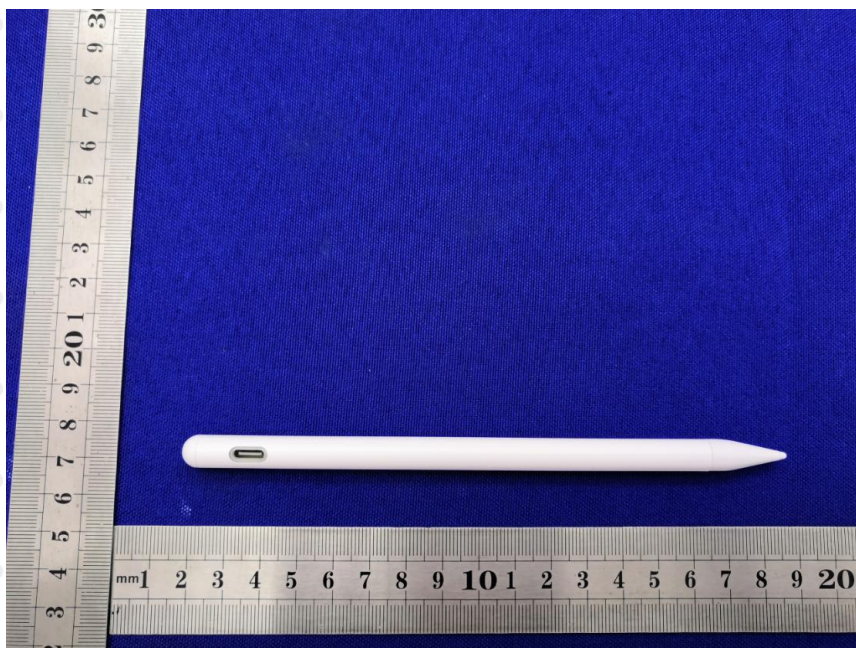

End of report